

# Ritters

## HYDRAULIC PRESSES



Quality Pneumatic & Hydraulic Products



Blanking



Forming

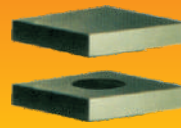

Moulding



Clamping

# 'C' FRAME PRESS

## TECHNICAL DATA



**WITH ANTI ROTATION GUIDE**

**WITH GUIDED MOVING PLATEN**

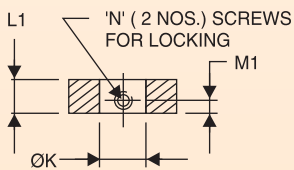
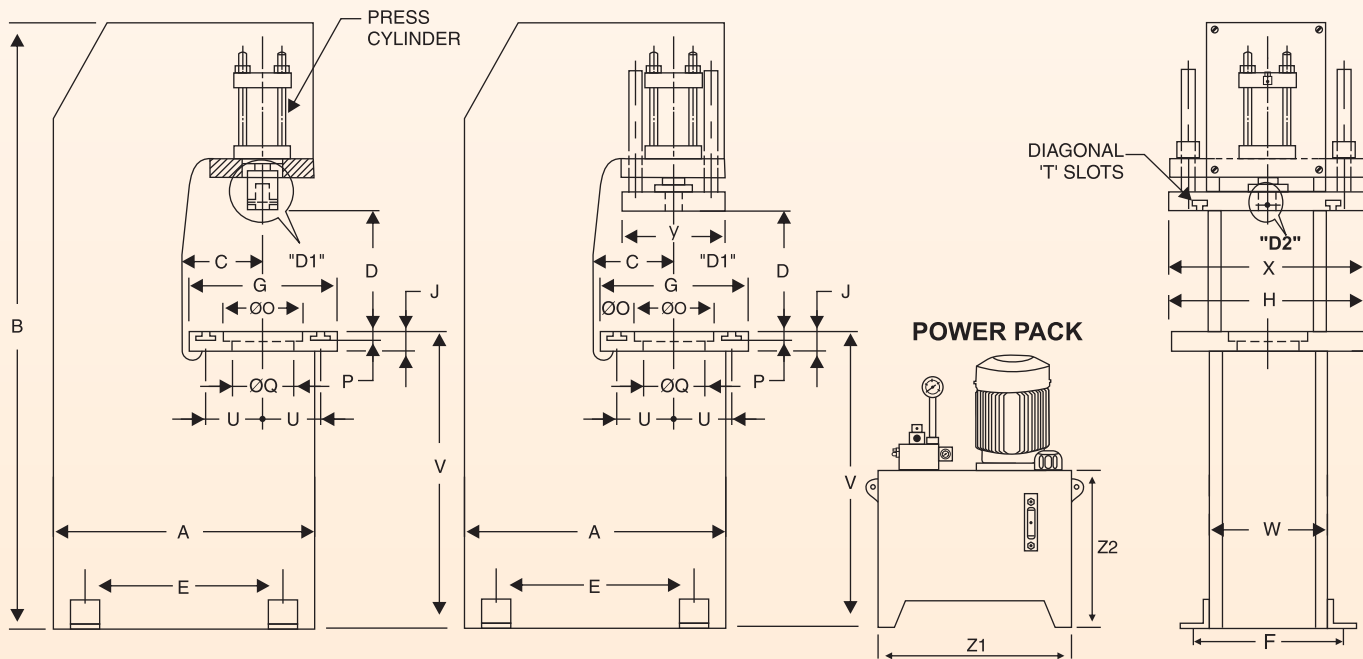

**DETAIL "D2"**

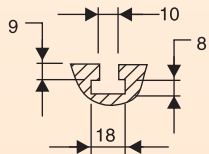

**T-10 'T' SLOT**

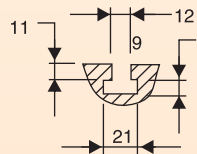

**T-12 'T' SLOT**

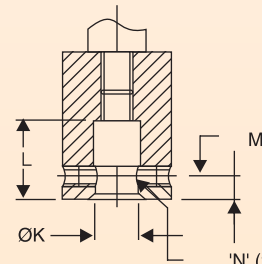

**DETAIL "D1"**

**'N' (2 NOS.) SCREWS FOR LOCKING**

WITH ARG	WITH GMP	TON	Motor (H.P.)	Speed (mm/sec.)	Oil Tank Cap.	Working Pressure (Kgf/Cm <sup>2</sup> )	A	B	C	D	E	F	G	H	J	ØK	L	L1	M	M1	N	ØO	P	ØQ	T	U	V	W	X	Y	Z1	Z2
RA-03-1CA	RA-03-1CG	3	2	64	60 lts.	100	550	1450	125	250	350	260	250	250	38	20	25	38	10	10	M6	60	18	45	10	75	880	355	275	200	450	450
RA-05-1CA	RA-05-1CG	5	3	59	80 lts.	100	600	1670	150	300	400	285	280	280	43	25	30	43	10	12	M8	75	18	55	10	100	945	355	340	200	500	500
RA-10-1CA	RA-10-1CG	10	5	63	100 lts.	100	650	1960	175	300	500	360	350	350	53	25	40	53	10	12	M8	105	20	75	12	100	950	400	420	230	550	550
RA-20-1CA	RA-20-1CG	20	5	40	150 lts.	170	700	1970	200	350	550	400	380	380	62	30	60	62	10	12	M8	130	25	90	12	125	950	400	450	250	600	600
RA-30-1CA	RA-30-1CG	30	7.5	61	200 lts.	250	900	1980	200	350	600	440	380	380	72	40	80	72	12	15	M10	130	25	90	12	125	950	400	500	250	650	650
RA-50-1CA	RA-50-1CG	50	7.5	42	250 lts.	285	1100	2250	200	400	750	475	400	400	80	40	80	72	12	20	M12	130	30	90	16	150	960	400	525	250	750	750

# 4 PILLAR PRESS

## TECHNICAL DATA

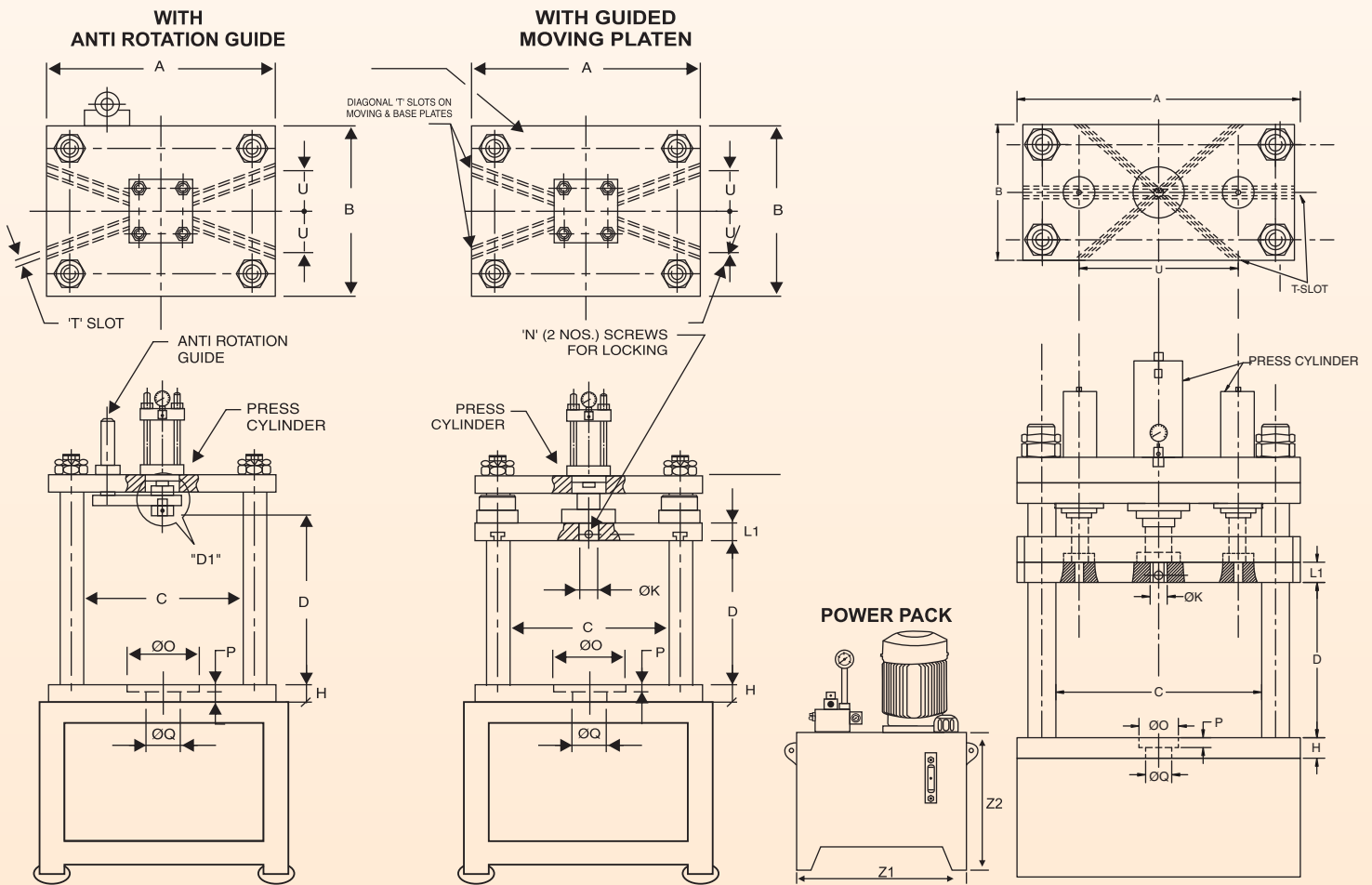

For 3, 5, 10, 20, 30, 50, 75 TON

For 3, 5, 10, 20, 30, 50, 75 TON

For 100, 200, 300, 500 TON

WITH ARG	WITH GMP	TON	Motor (H.P.)	Speed (mm/sec.)	Oil Tank Cap.	Working Pressure (Kg/Cm <sup>2</sup> )	A	B	C	D	H	ØK	L	L1	M	N	ØO	P	ØQ	T	W	U	Z1	Z2
RA-03-4PA	RA-03-4PG	3	2	43	60 lts.	100	350	300	250	270	32	20	25	32	10	M6	60	18	45	10	38	75	450	450
RA-05-4PA	RA-05-4PG	5	3	39	80 lts.	100	400	300	300	300	38	25	30	38	10	M8	75	18	55	10	50	75	500	500
RA-10-4PA	RA-10-4PG	10	5	40	100 lts.	130	500	350	350	350	53	25	40	53	10	M8	105	20	75	12	50	75	550	500
RA-20-4PA	RA-20-4PG	20	5	63/16	180 lts.	255	510	350	350	350	62	25	60	62	10	M8	130	25	90	16	60	80	600	600
RA-30-1CA	RA-30-1CG	30	7.5	61/13	250 lts.	250	590	400	400	400	72	30	80	72	10	M10	130	25	90	16	75	90	650	650
RA-50-1CA	RA-50-1CG	50	7.5	37/8	250 lts.	250	830	600	600	450	100	40	80	100	12	M12	130	30	90	16	80	100	750	700
RA-75-4PA	RA-75-4PG	75	10	31/8	350 lts.	240	840	700	700	500	110	40	80	110	16	M12	130	30	90	16	90	100	850	750
RA-100-4PA	RA-100-4PG	100	15	241/9	500 lts.	185	980	700	700	600	120	40	90	120	20	M12	150	40	100	20	100	450	1050	850
RA-200-4PA	RA-200-4G	200	20	200/5	700 lts.	190	1240	900	900	700	220	50	90	130	20	M12	150	40	100	20	120	600	1100	900
RA-300-4PA	RA-300-4PG	300	20	127/4	700 lts.	215	1270	900	900	700	260	50	90	130	25	M12	150	40	100	20	130	600	1150	950
RA-500-4PA	RA-500-4PA	500	25	100/5	900 lts.	215	1390	1000	1000	1100	300	60	100	150	25	M16	160	40	100	24	150	700	1200	1000



## Special Purpose Machines



Hydraulic Rubber  
Injection Moulding  
Machine



Pipe Flaring Machine



Pipe Squeezing  
Machine



Hydraulic Press 'C' Frame  
with load cell & safety guard



Hydro-Pneumatic Press  
with Indexing Table



High Speed Hydraulic Press



**Ritters Automation Pvt. Ltd.**

M-160, Sector-1, DSIDC, Bawana, New Delhi - 110039

Ph. : 27753720-1-2, Fax +91-11-27753719

Email : [info@rittersindia.com](mailto:info@rittersindia.com) Website : [www.rittersindia.com](http://www.rittersindia.com)