



Quality Pneumatic & Hydraulic Products
www.rittersindia.com



High Speed Hydraulic Press with Indexing Table

**Increases
Productivity
2-3 times**
by decreasing
Loading and
Unloading time.

Available in
**4,6,8 & 12
Stations**
in Standard
Models.

Available in
**3,5,10,15,20
& 30 Tons**
in Standard Models.



Scan for Youtube Video

 [RittersAutomationPvtLtd](https://www.youtube.com/RittersAutomationPvtLtd)

HIGH SPEED HYDRAULIC PRESS WITH INDEXING TABLE

TECHNICAL DATA

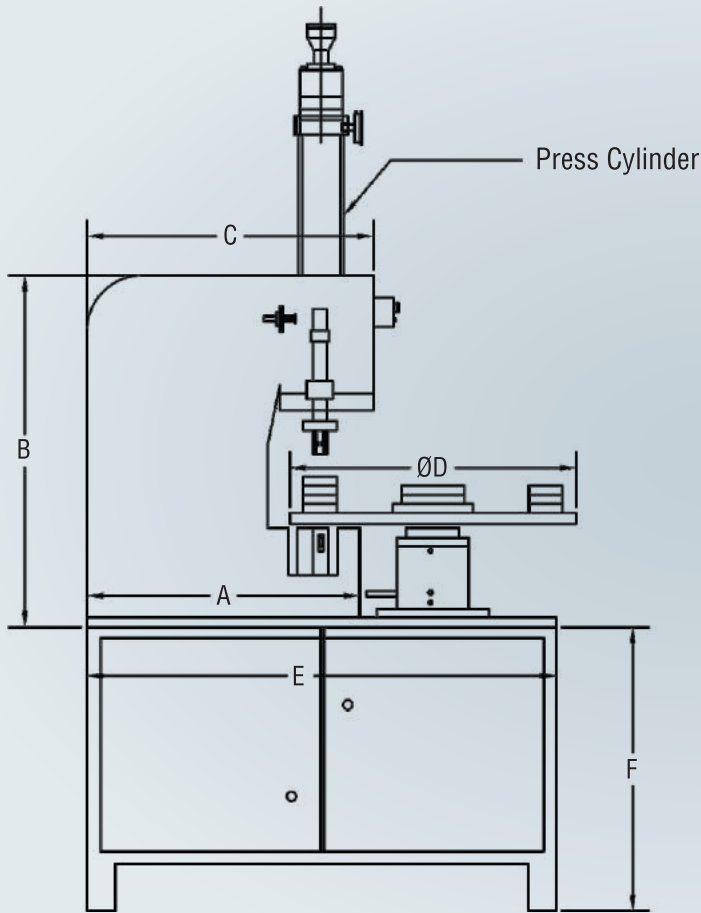

SIDE VIEW

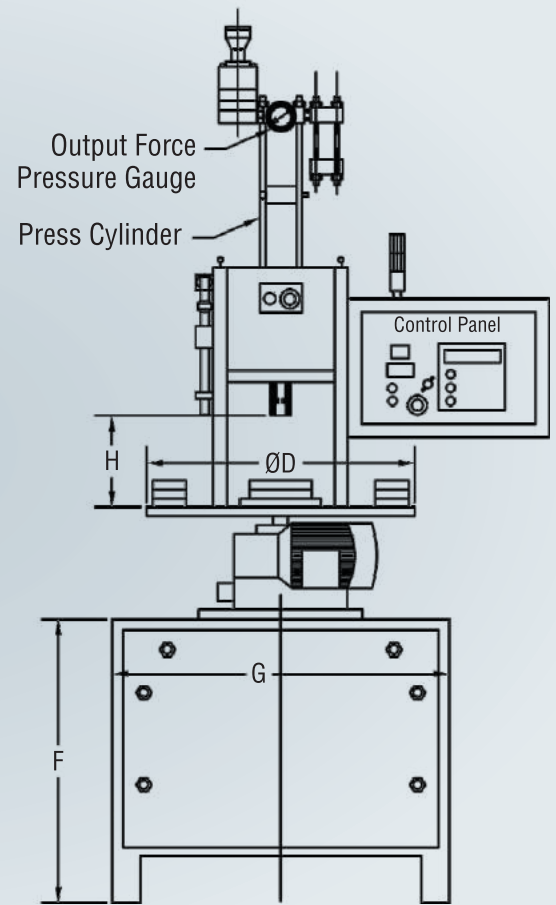

FRONT VIEW

Model No.	Ton	No. of Stations	HP	W.Pr	App/Ret Speed mm/Sec	Press Speed mm/sec	App/Ret Load kg	A	B	C	ØD	E	F	G	H
HSIT-03-*S	3	4/6/8/12	1.5	85	220	28	385	500	750	530	500	900	525	600	100
HSIT-05-*S	5	4/6/8/12	2	95	290	24	430	550	750	580	550	1000	530	700	100
HSIT-10-*S	10	4/6/8/12	3	120	200	19	990	600	785	640	600	1050	635	755	100
HSIT-15-*S	15	4/6/8/12	5	115	260	22	1310	640	900	700	650	1200	650	800	100
HSIT-20-*S	20	4/6/8/12	5	105	150	17	2300	670	1150	700	650	1300	650	900	150
HSIT-30-*S	30	4/6/8/12	7.5	135	175	10	3065	870	1150	900	700	1400	650	900	150

* No. of Indexing Stations.



Quality Pneumatic & Hydraulic Products



Ritters Automation Pvt. Ltd.

Plot No. 2, Street No. 9, Sector 7B, Model Economic Township, Sondhi, Distt. Jhajjar, Haryana 124103

+91-1251 351 246

info@rittersindia.com

marketing@rittersindia.com

www.rittersautomation.in